

FLUE INSTALLATION FOR PARTIAL MASONRY CHIMNEY

Using brickwork from floor to ceiling and triple skin flue through roof

NOTES:

- [1] Determine height of deflector to suit brick course and cut starter flue to achieve setup as per drawing.
- [2] Fit flue adaptor into cast iron collar of firebox gather. Fit starter flue (with gussets) into flue adaptor. Drill through collar and secure with stainless steel screws or rivets x 3.
- [3] All stainless steel inner flues must be joined using stainless steel pop rivets.
- [4] Set deflector plate into course of brickwork by approx 30mm to ensure good seat. The plate also rests on the top of the starter flue gussets.
- [5] The starter triple (with slots and cap) is then placed on top of the deflector plate.
- [6] Place rockwool blanket (aluminium side down) on top of deflector plate ensuring complete coverage up to sides of brick enclosure and a neat fit around the triple flue. The slots in the starter triple must be approx 100mm above the top of the rockwool.
- [7] 50mm clearance is required from outer casing to timbers and other combustible material.
- [8] Pick up weight of outer casing in roof space. The weight of the casing must not be supported by the gussets alone.
- [9] At the termination height of the triple flue the active stainless steel inner must be 30mm higher than the middle and outer galvanised casing. The stainless steel skirt is screwed to the crimp of the outer casing. The stainless steel cowl slides into the neck of the skirt and must locate inside the active flue below. No fixing is to be done to the cowl.
- [10] For exempt model heat transfer is required as per product instruction details.

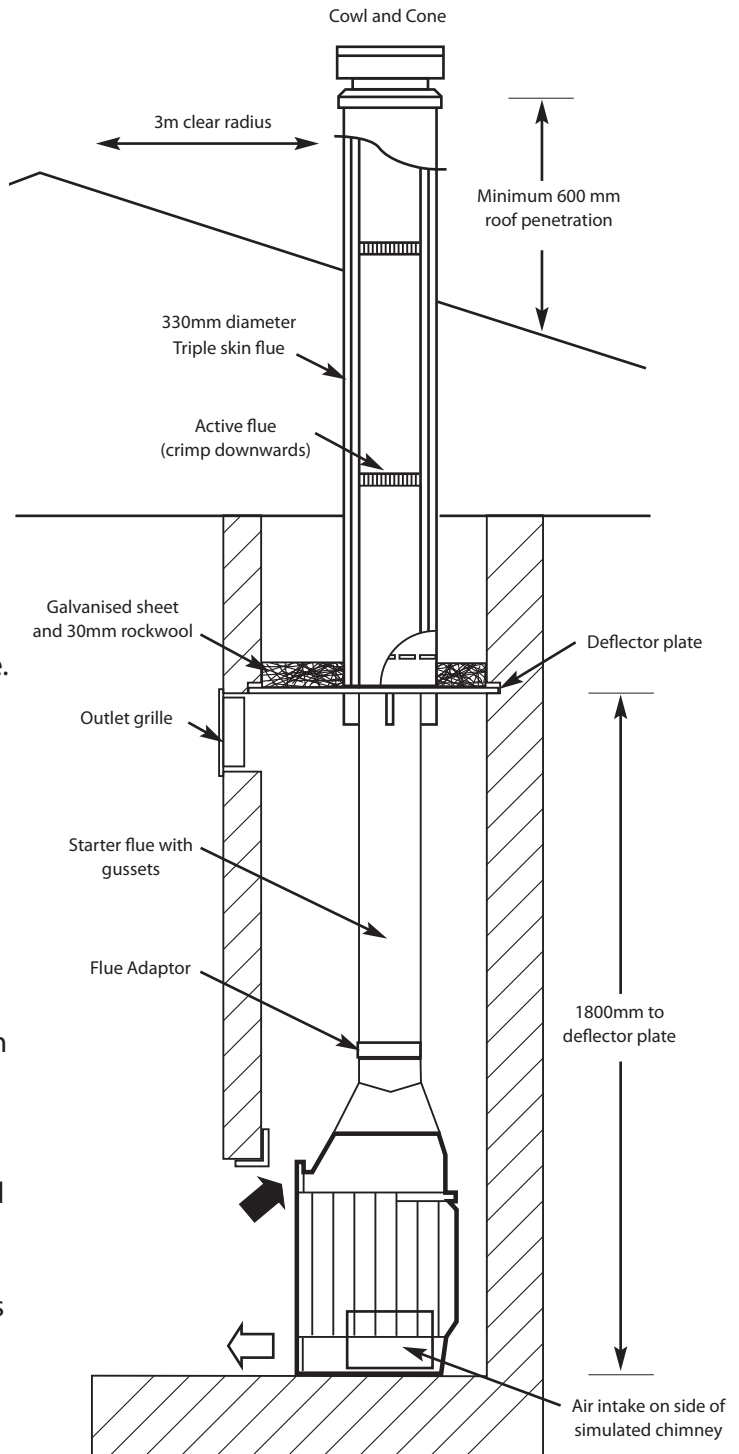

IMPORTANT: Appliance and Flue kit to be strictly installed in accordance to AS/NZS 2918:2001 and the appropriate requirements of the relevant codes. Installer to be a qualified licensed person.

**CHEMINÉES
PHILIPPE
AUSTRALIA**

430 Johnston St., Abbotsford, Victoria 3067 Phone: 03 9417 3315
e-mail: sales@wignells.com.au www.chemphilaust.com.au